

COMBO UNIT VALUE SERIES

 First in Quality. Built to Last.



COMBO UNIT

VALUE SERIES

MODELS

VS1620T, VS1620TK

A PERFECT MATCH

The Value Series Combo Unit combines a rugged EASTEY L-sealer and shrink tunnel on a common frame with one power source. This allows for quick setup, perfect alignment and consistent product sealing. A common base with casters makes this a very portable system for transportation within the plant.

BUILT RIGHT...PRICED RIGHT

Proven reliable over and over again, these intermediate level EASTEY L-Sealers provide you with all the quality features found in much higher priced machines. The seal head features our proven hot knife seal system to provide a positive seal on a wide variety of films including polyethylene, polyolefin, and PVC.

RUGGED DESIGN

EASTEY Value Series Combo Unit are expertly welded on 12 gauge steel frames and designed to handle the day to day abuse of manual sealing in most shrink wrap applications. Rugged seal arms and magnet clamping are just some of the features that provide the durability you have come to rely on from EASTEY. See for yourself why EASTEY has been a leader in the shrink packaging industry for over 25 years.

RELIABLE SEMI-AUTOMATIC L-SEALING

Easteey's Value Series Combo Unit offers a L-sealer and shrink tunnel on a common frame for simple setup, perfect alignment and mobility within the plant.

STANDARD FEATURES

- Seal head system available as a hot knife or hot band depending on your application
- Designed to seal polyethylene, polyolefin or PVC shrink films
- All-welded main frame from 12 gauge steel
- Seal head equipped with gas shock head return
- Dual locking magnet clamps apply consistent pressure across seal bar
- Automatic cycle timing with adjustable dwell time
- Solid state temperature control adjustable for a variety of films
- Wide product tray provides large work area
- Seal head can be raised or lowered to center-seal product
- Film rack positioned beneath product tray for simple film loading
- Adjustable pin perforator provides air evacuation
- Positive shrinking of all products assured with consistent air flow
- 15" wide x 8" tall x 26" long chamber
- Variable speed tunnel conveyor and variable air flow for a variety of shrink applications
- Rugged stainless steel mesh belt conveyor or live roller conveyor on tunnel
- Seal size of 16" x 20"
- Maximum film width up to 18"
- Heavy duty casters for transportation within plant
- Easy to use design requires minimal training and maintenance



COMBO UNIT VALUE SERIES

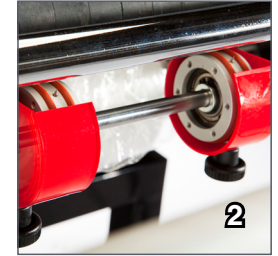
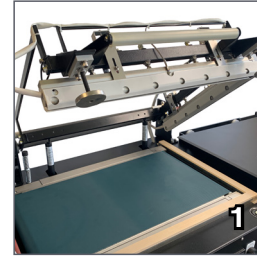

1. Takeaway Conveyor

Seal head can be raised or lowered to center the seal on your product

2. Pin Perf

Adjustable pin perforator provides air evacuation in film which allows for proper film shrinkage

3. Seal Head Options

Seal head system available as hot knife or hot band depending on your application

4. Inside of Tunnel

Consistent air flow provides positive shrinking of polyolefin or PVC shrink films

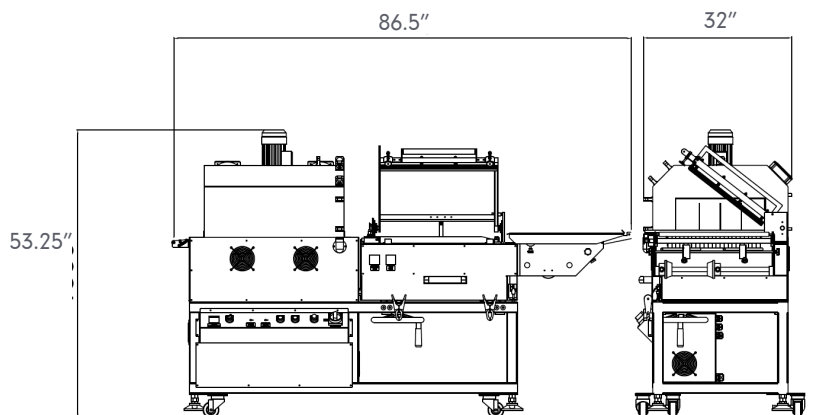

MODEL NUMBER	MACHINE DIMENSIONS			CHAMBER DIMENSIONS			CONVEYOR	CONVEYOR	STANDARD POWER			WEIGHT	SHP WT.
	WIDTH	HEIGHT	LENGTH	WIDTH	HEIGHT	LENGTH	WIDTH	LENGTH	VOLTS	AMPS	PHASE		
VS1620TK	32"	53.25"	86.5"	16"	7"	26"	13.5"	24"	220	30	1	650 lbs	750 lbs
	81 cm	134 cm	218 cm	41 cm	18 cm	66 cm	34 cm	61 cm					



7041 Boone Avenue North, Brooklyn Park, MN 55428
 (763) 428-4846 1 (800) 835-9344
 www.eastey.com info@eastey.com



ENGAGE technologies corporation

112723 Rev B